

1E3108

Total No. of Questions : 22

Total No. of Pages : 04

Roll No. :

1E3108

B.Tech. I-Sem. (Main/Back) Exam. - 2024

IFY3-08 / Basic Electrical Engineering

Time : 3 Hours

Maximum Marks : 70

Instructions to Candidates :

Attempt all ten questions from Part A, five questions out of seven questions from Part B and three questions out of five questions from Part C.

Schematic diagrams must be shown wherever necessary. Any data you feel missing suitably be assumed and stated clearly. Units of quantities used/ calculated must be stated clearly.

Use of following supporting material is permitted during examination.

(Mentioned in form No.205)

1.

2.

PART-A

(Answer should be given upto 25 words only)

All questions are compulsory

[10x2=20]

Q.1. State the relationship between line voltage and phase voltage and line current and phase current of a 3-phase delta connected system.

- Q.2. Define Apparent power and Power factor.
- Q.3. Why transformers are rated in kVA?
- Q.4. Give the emf equation of a transformer and define each term.
- Q.5. An 1100/400 V, 50 Hz single phase transformer has 100 turns on the secondary winding. Calculate the number of turns on its primary winding.
- Q.6. Write down the expression of equivalent resistance for 'n'-number of resistors in parallel connection.
- Q.7. Write the algorithm for Nodal Analysis.
- Q.8. Distinguish between induction motor and synchronous motor.
- Q.9. Draw the V-I characteristics of an ideal diode.
- Q.10. Give some method available for measuring 3-phase power.

PART-B

(Analytical / Problem solving questions)

Attempt any five questions

[5x4=20]

- Q.1. An alternating voltage is given by $V=230\sin 314t$. Calculate :
- (i) Frequency
 - (ii) Maximum value
 - (iii) Average value
 - (iv) RMS value

- Q.2 State Thevenin's theorem and give a proof. Apply this theorem to calculate the current passing through the 4Ω resistor of the circuit of Fig. 1

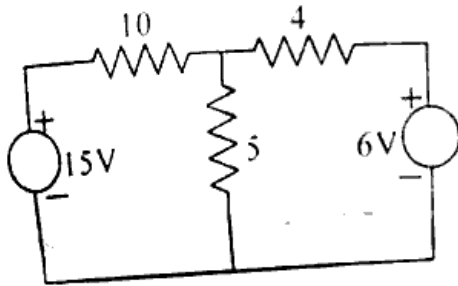

Fig. 1

- Q.3. Determine the power factor of a RLC series circuit with $R = 5$ ohm, $X_L = 8$ ohm and $X_C = 12$ ohm.
- Q.4. With a neat diagram explain the working of a PN junction diode in forward bias and reverse bias and show the effect of temperature on its V-I characteristics.
- Q.5. List out the characteristics of DC motor.
- Q.6. Derive an expression for conversion of a resistive network from star to delta.
- Q.7. What is working of BJT? Draw its equivalent circuit.

PART-C

(Descriptive/Analytical/Problem solving/ Design questions)

Attempt any three questions

[3x10=30]

- Q.1. Explain with sketches the constructional features and working of a synchronous generator.
- Q.2. In a series circuit containing pure resistance and a pure inductance, the current and the voltage are expressed as :

$$i(t) = 5 \sin\left(314t + \frac{2\pi}{3}\right) \text{ and } v(t) = 15 \sin\left(314t + \frac{5\pi}{6}\right)$$

- (a) What is the impedance of the circuit?
- (b) What is the value of the resistance?
- (c) What is the inductance in henrys?
- (d) What is the average power drawn by the circuit?
- (e) What is the power factor?

Q.3. What is a SCR? Sketch V-I characteristics of Thyristor. Label the various voltages current and operating mode on this sketch.

Q.4. Explain Superposition theorem. Use the superposition theorem to find ' I ' in the circuit shown in Fig. 2.

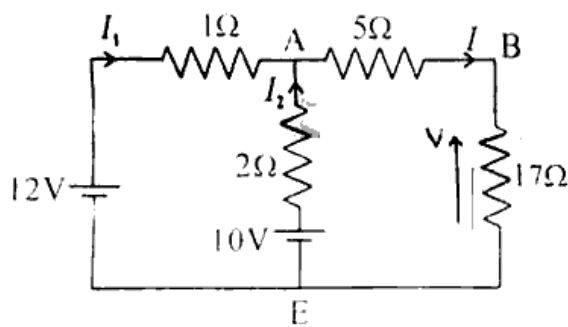

Fig. 2

Q.5. Write short notes on the following :

- (i) ELCB
- (ii) SFU

-----X-----