

1E3108

Roll No. _____

Total No. of Pages: **4****1E3108****B. Tech. I - Sem. (Main / Back) Exam., - 2025
1FY3-08 Basic Electrical Engineering****Time: 3 Hours****Maximum Marks: 70***Instructions to Candidates:**Attempt all ten questions from Part A, five questions out of seven questions from Part B and three questions out of five from Part C.**Schematic diagrams must be shown wherever necessary. Any data you feel missing may suitably be assumed and stated clearly. Units of quantities used /calculated must be stated clearly.**Use of following supporting material is permitted during examination.
(Mentioned in form No. 205)*

1. NIL _____ 2. NIL _____

PART – A**[10×2=20]****(Answer should be given up to 25 words only)****All questions are compulsory**

- Q.1 Define apparent power and power factor.
Q.2 Write the EMF equation of a transformer and define each term.
Q.3 If the length a wire of resistance R is uniformly stretched to n times its original value, then what is the value of its new resistance?
Q.4 Name and state the principle on which transformer works.
Q.5 State the torque-slip characteristic of an Induction motor.

- Q.6 Write the full form of MCB. Where it is used?
- Q.7 What is the significance of reactive power?
- Q.8 What do you understand by lamination in a transformer?
- Q.9 Distinguish between a rectifier and an inverter.
- Q.10 What are the transformer losses?

PART - B

[5×4=20]

(Analytical/Problem solving questions)

Attempt any five questions

- Q.1 Determine the power factor of a RLC series circuit with $R = 5$ ohms, $X_L = 8$ ohms, and $X_C = 12$ ohms.
- Q.2 Find the current through 5 ohm resistance using Thevenin's theorem in following circuit:

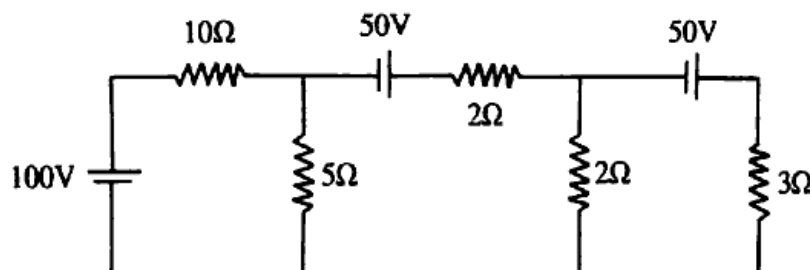

- Q.3 With a neat circuit diagram explain the construction and operating principle of a DC machine. <https://www.pyqonline.com>
- Q.4 Derive EMF equation of a single phase transformer. Discuss why transformer is known as constant flux device.
- Q.5 Explain the structure of NPN and PNP transistors in detail.
- Q.6 Write a short note on commutators.
- Q.7 Explain star to delta and delta to star transformation.

PART - C

[3×10=30]

(Descriptive/Analytical/Problem Solving/Design Questions)

Attempt any three questions

- Q.1 Explain with sketches the constructional features and working of a synchronous generator.
- Q.2 A 100 ohms resistance is connected in series with a choke coil. On applying a 400 V, 50 Hz supply to this combination, the voltage across resistance and choke coil are 200 V and 300 V respectively. Find the power consumed by the choke coil. Also calculate the power of a choke coil and the power factor of circuit.
- Q.3 Use superposition theorem to find the current in 40 ohms resistance in the circuit shown below (assume all resistances in ohms) :

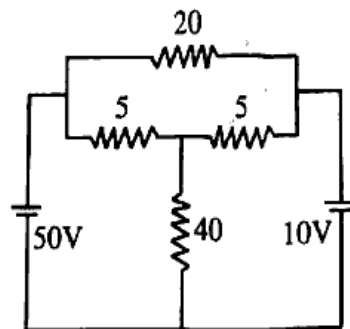

- Q.4 Explain why protective devices are used for overload and short circuit protection. Also explain why do we use an ELCB in electrical circuit installation?
- Q.5 The load of a household consists of 8 lamps of 20W each, 4 fans of 75W each, 1 T.V. of 40W, 1 refrigerator of 150W, 1 AC of 1.5 kW, 1 heater of 1.8 kW, and 1 washing machine of 900W. If the supply is 230 Volts and fixed monthly meter charges are ₹ 150. Then for average loading of 50% throughout a day, what will be the electricity bill? Assume the cost per unit for first 800 units be ₹ 4, next 500 units be ₹ 5 and after that ₹ 6 per unit.